

# Intelligent School Energy Monitoring Solution

Educational Renewable Power and Energy Consumption Measurement and Demonstration Platform

With the increasing requirements for environmental and energy education for schools, GEOPROTEK extends the PV renewable energy monitoring to energy consumption measurement. System integrators can apply GS LOGGER not only to monitor the PV power yield, but also can monitoring the power consumption for each classrooms, each floor or each buildings. In order to meet different school display requirements, GS LOGGER allow system integrator to help end user to customized the display screen, yield graph, comparison chart, pictures, or videos to maximize the customers satisfaction. Also, it can be used to demonstrate the result of renewable energy and students energy saving. Students can easily check the result of their energy saving and compare with history energy usage and with other classrooms. With the graphic display, school can combine with course to illustrate students how the PV system works, how the importance of energy saving, and how much they contribute to the world in saving CO2 reduction, forest protection.



# One Platform with All-in-One Function

## Presentation, Monitoring, Management

In a solar system, the solar arrays will connect to the PV Inverter to transfer the DC power to AC power and feed into the grid. In one PV system, there may have more than one PV inverters in a solar system. Usually, the PV inverters are located near the solar arrays to decrease the loss and GS LOGGER is located near the demonstration TV. The GS LOGGER will communicate with PV inverter through RS485 interface. The maximum distance of RS485 communication is around hundred of meters. It also can serial connected with all the PV inverters you need to monitor. If the GS LOGGER and PV inverters are in different buildings, you can consider to apply Ethernet to RS485 converter that GS LOGGER can communicate with PV inverters through local network.

For a power consumption measurement, you can put the AC power meter in individual classroom or in the central AC panel which you plan to monitor. All the AC meters can serial connected with RS485 interface and communicate with GS LOGGER. If you need to measure the temperature, irradiation, wind speed, humidity...etc environment parameters, you also can connect with an individual RS485 port to GS LOGGER. By this way, all the data will be monitored and central management in GS LOGGER, you can build up your display pages and show the information you need on the demonstration TFT LCD. Once you connect GS LOGGER to the internet, it will be with remote monitoring function services like GeoSolarPortal, GS Mobile, Email...etc.

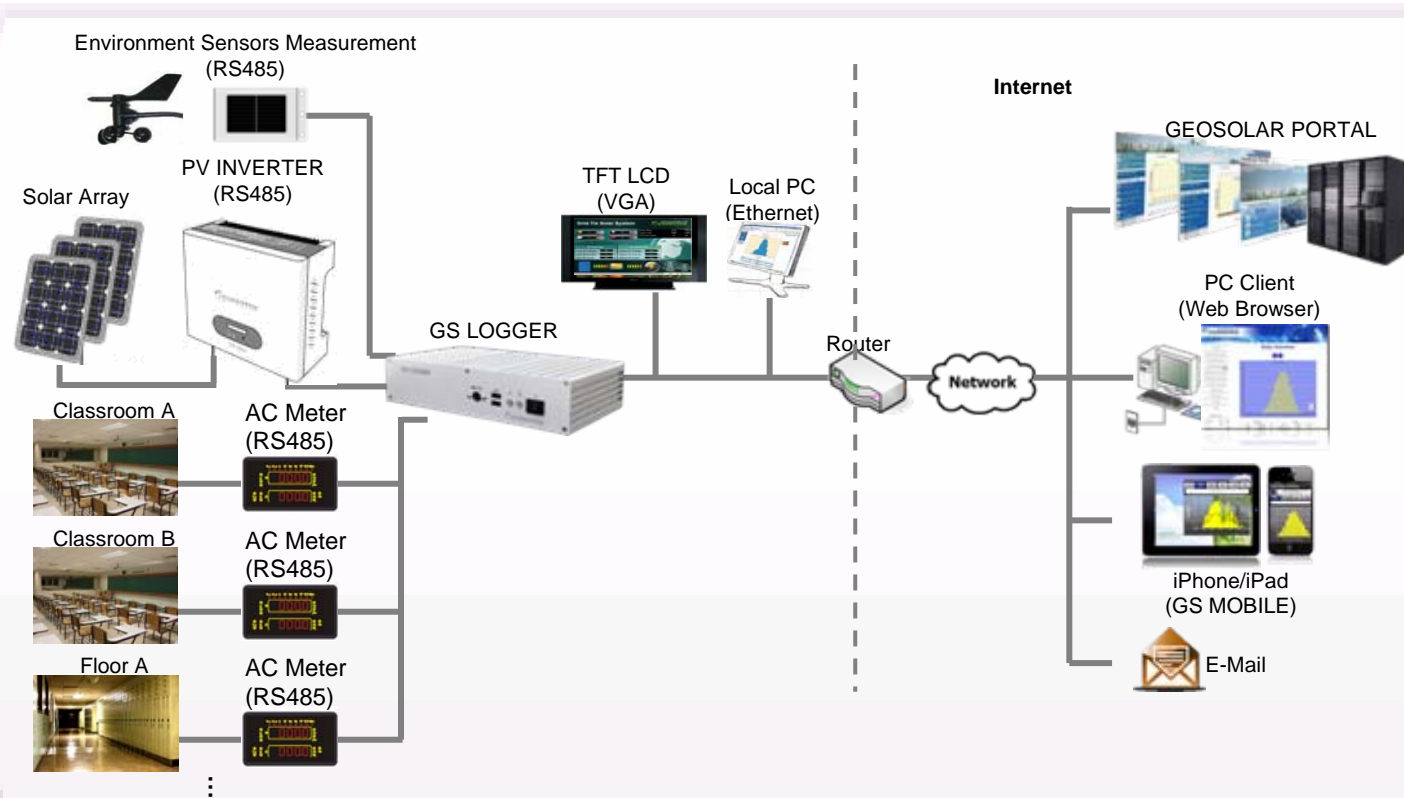

## Measurement & Demonstration

### Solar Power Yield Demonstration

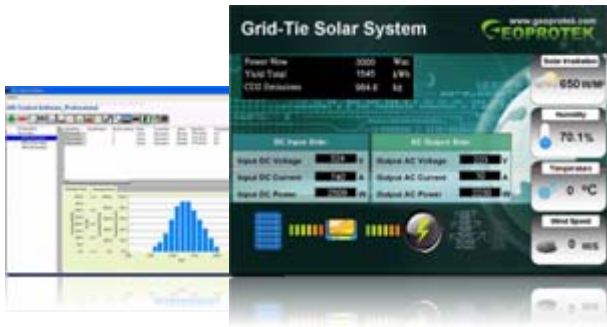

Once schools installed a solar system, they hope to illustrate how it works and how much it yield or contribute to the world. By connecting the RS485 port on PV inverters to GS LOGGER, GS LOGGER will query the data from the inverters, record it into memory, and make static data report. In the display screen, students can realize what is DC power, what is AC power, what component transfer the power, and what is the relationship between weather and solar power. It also can shows the yield graph that make students know how much power of the solar system can generate in one day, one week, one month, or one year. Also they can understand the relation with CO2 emission reduction, forest protection area... etc environment awareness.

---

### Energy Consumption Demonstration



In most of school, they hope to not only know how much the renewable energy yield, but also how much energy their students saved. By installing an AC power meter in each unit (classroom, floor or building) and connect it to GS LOGGER via RS485 interface, students can understand how much energy they use today, this week or this month. They also can compare the energy usage with last year in the same month to check whether their effort on energy saving workable or not and provide them more achievement and motivation to keep going. Students can check the result in real time and modify their behavior. The best award is to show it out and demonstrate the energy saving result.

---

### Environment Parameter Measurement



Usually, a solar system, wind power system, or energy usage are very highly related to weather condition like solar irradiation, wind speed, temperature, or humidity. For a solar power system may show the graph of solar power, irradiation, and temperature curves. For a wind power system may show the graph between wind power and wind speed. For energy consumption may show the graph between energy usage and temperature. Students can check the relationship between them and understand the climate changes. For advanced users, they can download data from GS LOGGER for further analysis and study.

## Applications

### Energy Education



With the global warming issue is getting more and more critical, we have the responsibility to let our next generation to know the crisis and aware the important of that. School is the best place and the only way they can learn and work together. We have the duty to establish the learning environment for students. Intelligent energy monitoring solution is only a tool, schools can combine with courses or competition to build up an environment that students can “do” by themselves. To make students know the earth protection is not only a word, but an action need they start to work on it.

---

### School Energy Saving Competition

Many students know the issue of energy saving. But the truly concept of energy saving need to be aware and put into action. A energy saving competition is a good way to achieve that. Many schools promote the energy saving concept, but students can not know the effect and whether the methods is correct or not. Only with a truly quantified data demonstration can make students to real time check the result and adjust their energy saving behavior to the right way. A competition can make students with more honor on it and full of achievement. It's the best way to let students to show how they achieve that and how good they have done.



---

### Combine with Teaching Courses

There are more and more schools start to have the courses teaching about renewable energy or energy saving. With the intelligent energy monitoring, teachers can start to design more and more diversity courses. For example, they can design a course start with the theory of solar power, solar system, then show it on site and the TFT LCD illustrate how it works and how much it yield. In computer class, they can review the result remotely by PC with web browser or by a mobile device (like iPhone/iPad). A good teaching course design, students can easily link their learning in the class with what they see in the real world.



## Features

### Design Your Own Display Pages

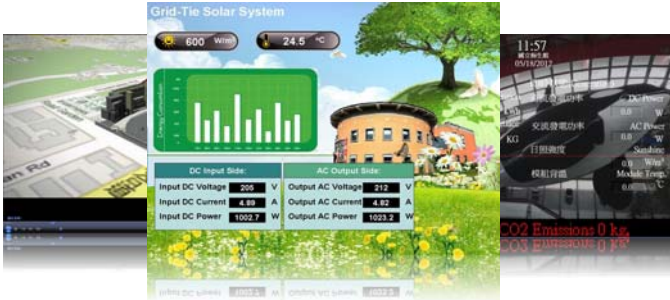

Most of system integrators takes lots of cost and effort on developing new software to meet different customers requirements. The cost is high and the stability is poor. In order to help system integrators to solve this issue, GS LOGGER provide a standard software that allows system installer to add new devices and help end user to design the display pages they want. You can add multiple display pages to display different information, pictures, even videos to introduce the school or systems. In each page, you can setup the properties like background, indicator position, data source, color, size... etc. Also you can add the graph in the display pages to show the solar yield curves or power consumption comparison bar chart...etc. For this powerful and flexible features, system integrators can design pages to satisfy customers requirements more precisely and easily in very short time.

---

### Future Expansion Flexibility



Future expansion is always the most important consideration for schools and system installers. For schools, they may have limited budget to complete initial part of buildings at first time, but look forward to expand to other buildings in the future. For system installers, they also look forward to a long term business relationship with their customers. GS LOGGER provides great flexibility for future expansion and integration. You can add more PV inverters for larger solar system, more AC meters for more classrooms power consumption measurements, or more sensors for more environment measurements with additional software licenses. You can complete the intelligent school monitoring platform step by step gradually.

---

### Data Tracing and Cloud Service



Many users need to download data for further analysis or data tracing. Each GS LOGGER can periodically record the monitoring data in .CSV excel file format, users can download data via FTP client. Or school MIS can install a PC to backup the data by FTP push automatically. Once the GS LOGGER connect to the internet, it will also send data to remote cloud server periodically. School managers or system administrators can check all the data anytime anywhere by their PC or mobile device. School MIS can make a linkage in the school website to show the result and achievement of the effort.

More Than 2000 On-Line Real Example Sites...

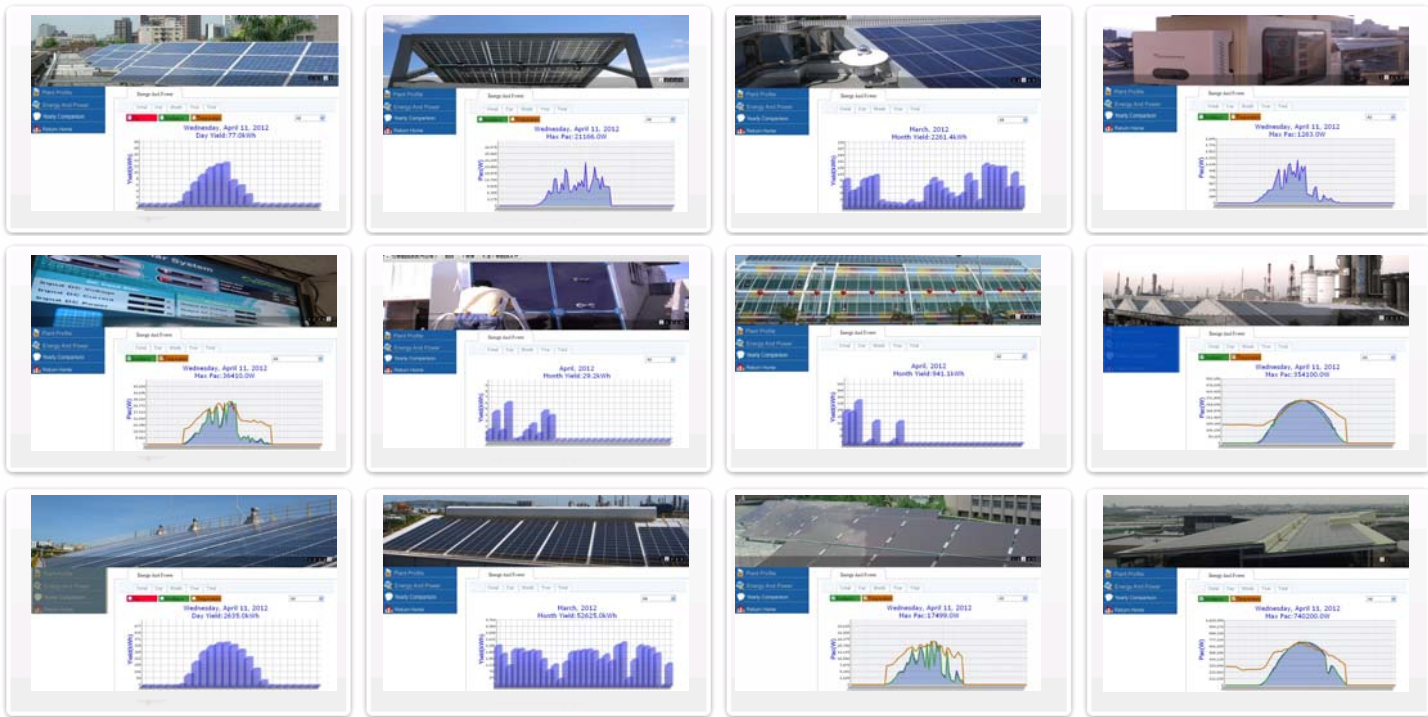

Visit the Example Sites? Please Go To...

[www.GeoSolarPortal.com](http://www.GeoSolarPortal.com)

**GEOPROTEK SOLAR TECHNOLOGY**

TEL: +886 2 26597969

FAX: +886 2 26597678

Email: [service@geoprotek.com](mailto:service@geoprotek.com)

[www.geoprotek.com](http://www.geoprotek.com)





**NOW  
YOU CAN**  
*Change*  
**YOUR LIFE**